

Cosy-floor kits 4 & 5

Installation Guide

Maximum Area 20m²



**PLEASE READ THIS INSTALLATION GUIDE CAREFULLY
BEFORE BEGINNING ANY WORK
TO ENSURE A SAFE & TROUBLE FREE INSTALLATION.**

Parts provided with pack 4

100m of 16mm pert-al-pert pipe
200 no. push in pipe clips
1 no. reliance compact UFH Control unit
*1 no 1/2" M.I. x 16mm. Pert-al-Pert straight con
*1 no. 1/2" M.I x 16mm Pert-al-Pert Elbow
25 met. 130mm x 8mm edge insulation.

Parts provided with pack 5

100m of 18mm pert-al-pert pipe
200 no. push in pipe clips
1 no. reliance compact UFH control unit
*1 no 1/2" M.I x 18mm. Pert-al-Pert straight con
*1 no 1/2" M.I x 16mm. Pert-al-Pert Elbow
25met. 130mm x 8mm edge insulation

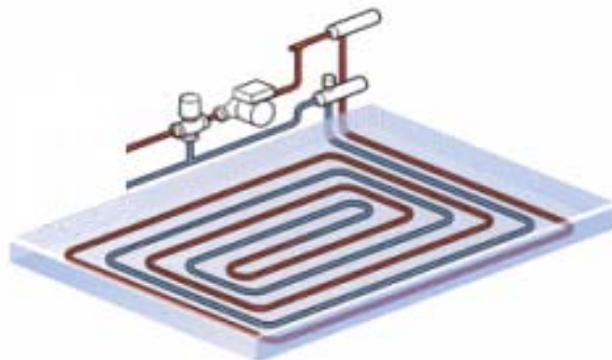

* = Fittings for connecting floor heating pipe to Reliance Compact.
We supply Pipe Cutters, Reamers, and Room Thermostats as optional extras.

**CHECK THAT ALL THE ABOVE COMPONENTS
ARE PACKED IN THE DELIVERY BOX.**

**ANY MISSING ITEMS MUST BE REPORTED TO TOTALFLOOR HEATING
WITHIN 48 HOURS (2 working days) OF RECEIPT OF GOODS.**

**ANY ITEMS REPORTED MISSING AFTER THIS PERIOD
WILL ONLY BE REPLACED AT CUSTOMERS EXPENSE.**

Floor Preparation:

Begin by ensuring the floor is clean and dry - natural 'curing' of the sub-floor or slab should be complete. You should allow for a suitable depth of insulation and approx. 65mm screed (4:1 sand to cement mix).

Insulation:

Begin by fixing a strip of edge insulation around the perimeter of the room. This will prevent a 'cold bridge' between the warm floor and the cold walls of the room. The edge insulation should be equivalent in height to the depth of floor insulation plus floor screed.

Floor insulation is laid in a staggered pattern, holding the edge insulation in place against the wall. This staggered pattern prevents any continuous cold gaps between the insulation. The joints between insulation sheets should be taped to prevent any movement when laying tubing and to give a good seal.

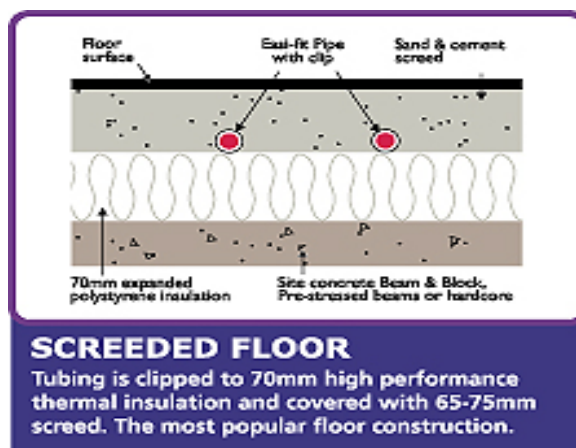

** If damp proof membrane is used it **must not** be fitted on top of the tubing. The tubing must be in direct contact with the screed.*

Prepare floor to accept Pert-al-Pert pipe. Recommended floor construction is a screed on at least 50mm expanded polystyrene insulation or similar, as shown above is best. For high heat loss areas e.g. conservatories we recommend tiled floor or ceramic slate etc for best effect.

Installation:

Roll tubing out hand over hand as per diagram opposite.

The tubing should be clipped to insulation using the clips provided. Intervals for clipping should be every metre, however more clips can be used at bends where necessary.



Pipe Layout:

The 'serpentine' arrangement as shown below is an example of the tubing layout for a typical conservatory. This layout gives a good even heat spread across the floor surface and avoids tight bends in the pipe.

It does however lend itself best to rectangular areas - for odd shaped rooms or conservatories we can provide a CAD drawing on request, otherwise use the spacing guide below. Note that the flow pipe into the room immediately follows the perimeter of the room to heat the coldest areas, i.e. outside walls, windows and doors etc.

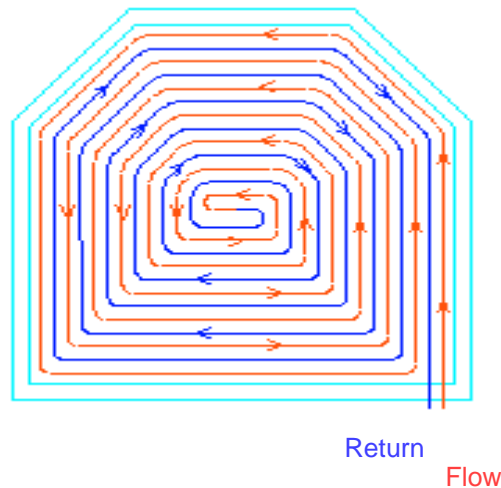

Remember to leave double spacing when working towards the centre of the room, then fill it in on the way back!

Distance from wall to first pipe = half the spacing between pipes, i.e. If overall pipe spacing is 180mm centres, then the distance from the wall to the first pipe should be 90mm.

Conservatory diagram:

In certain cases and for a small design fee a Computer Aided Design (CAD) drawing can be provided by Total Floor Heating showing the exact layout of tubing.



Whilst the Pert-al-Pert tubing is flexible and form stable care should be taken at bends i.e. bend slowly to avoid kinking. For doubling back where the pipe spacing is less than 200mm it is easier to form a bulb shape as diagram above, this will help to avoid kinking the pipe.

An approximate spacing guide to fully use the 100 metre roll provided is as follows:

- 20sqm - 200mm center to center
- 18sqm - 180mm centre to centre
- 17sqm - 170mm centre to centre
- 16sqm - 160mm centre to centre
- 15sqm - 150mm centre to centre
- 10sqm - 100mm center to center

Fitting the Pump Unit:

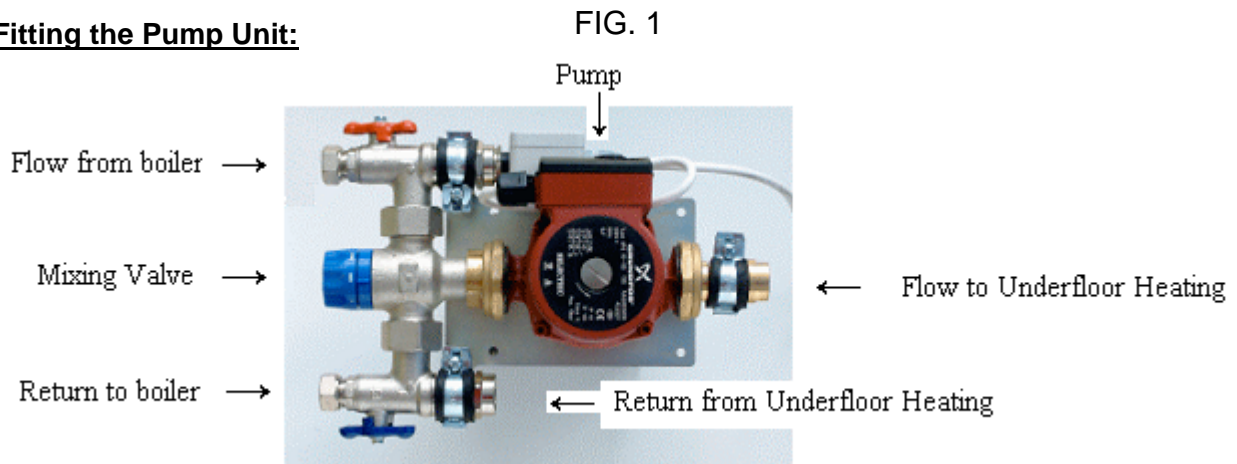

Fit the Reliance compact UFH control unit as shown in the booklet provided. The unit should be installed as close as possible to the room where the floor is to be heated.

The flow to the underfloor should be connected to the right hand side of the pump using one of the connections supplied and the return from the underfloor should be connected to the right hand side of the blue valve using the other connection provided. We recommend that these connections should be sealed with PTFE Tape or similar.

The tubing can be filled and pressure tested as follows:

- (a) Connect a hose to the valve with the blue head and take it to a drain outside, open the valve.
- (b) Connect a hose from a mains water tap to the valve with the red head. Open the tap and the valve to allow water to fill the tubing. This will drain to the outside.
- (c) When the water is running clear i.e. there are no air bubbles in the system, close the blue valve and after a short space of time close the red valve and the tap. The tubing will now be pressurised to mains pressure and ready for screeding.

Note: it may take several minutes for the system to fill and for the water to run clear to the drain. Please wait for the water to be free from air bubbles, this will ensure effective and silent running of the system and avoid any air locks later.

Normal test pressure is 3-4 bar, this should be possible with mains pressure but if not it can be topped up with a test pump.

Connection to existing system: (Floor Heating dependant on overall heating system being on)

The primary flow and return to the Reliance compact pump unit can be taken of anywhere on the existing radiator system, however minimum pipe size is 15mm and you should insure that there is sufficient capacity at the point of connection to take the additional heating load without adversely effecting the existing system. You should also insure that that the boiler has enough capacity for the additional heating load

Wiring

Wiring should be as per the wiring diagram in the Reliance compact kit.

* Note when the system is connected this way the underfloor heating will only operate when the original house heating is on. Bear in mind that the underfloor heating may need a longer heat up time than conventional radiators. The Reliance compact kit has an inbuilt stat which prevents the pump running when the overall system is cold.

Connection to existing system: (with independent control of underfloor heating)

This is the best method of connection if it is possible as it gives independent control of underfloor heating. A typical installation is shown on fig. (1).

Wiring: As shown on fig. (2).

Electric's & Wiring:

An electrical diagram and a Plumbing schematic is shown attached, they represent the most typical installations and are a guide only.

For the sake of clarity earth wires are not shown but should be installed where necessary. Zone valves are to be installed on primary circuits i.e. Underfloor, Radiators and hot water, they should be 4 wire type i.e. with auxiliary switch.



All wiring should be carried out by a suitably qualified person and should comply with current IEE Regulations.

Setting System to Work:

Hot water from the boiler or supply must be connected to the fitting with the red valve, return to the heat supply must be via the fitting with the blue valve, as indicated in FIG.1.

When the system is plumbed and wired it can now be set to work.

The water temperature can be adjusted by the blue knob on the mixing valve. (Remember it may need unlocked first - see instructions)

See the Reliance instructions for heat outputs for each setting.

Room Control:

The room to be heated is controlled by a TPS Programmable Room Thermostat, supplied as an optional extra by Totalfloor Heating.

Instructions on:

- where the thermostat should be fitted in the room,
- how it is wired,
- how it is operated

are all described in the leaflet provided with the thermostat.

Underfloor Heating Systems should be turned on approximately 2 hours before comfort temperatures are required. Due to thermal lag-time the system can also be turned off approximately 2 hours before the end of the heating period.

Pump Speed:

Normal pump setting is **II**, however increasing the pump speed to **III** will increase the flow rate and improve the system response time.

Maintenance:

The pump unit and its valves will require servicing as per manufacturers instructions. When the system is not in use e.g. during summer months the system should be operated for 4-5 minutes each week to keep the pump, valves and controls from seizing.

Since the Pipe is buried in screed and does not corrode there is no maintenance requirement. All connections should be properly tightened and checked for leaks by installer.

Trouble Shooting:

Fault	Cause	Remedy
Pump fails to start	Supply failure	Check fuses and possible loose electrical connections
	Capacitor is defective	Replace the capacitor
	Pump blocked due to furred bearings	Change over to maximum speed for a short period or free the rotor with a screwdriver inserted in the slot of the shaft end
	Impurities in the pump	Dismantle and clean the pump
Noise in the system	Pump flow setting is too high	Change to a lower pump speed
	Air in the system	Vent the system
Noise in the pump	Air in the pump	Vent the pump
	Inlet pressure too low	Increase the inlet pressure or check the air volume in the expansion tank (if installed)

Technical:

If you have any difficulty please don't hesitate to contact us.

Totalfloor Heating
15 Scarva Road
Gilford
Craigavion
BT63 6BG

Tel: 0333 123 0138

Fax: 0333 123 0139

Mob: 07788875472

Email: info@totalfloorheating.com

Cosy-Floor 4 & 5 Independent Of Rest Of Heating System.

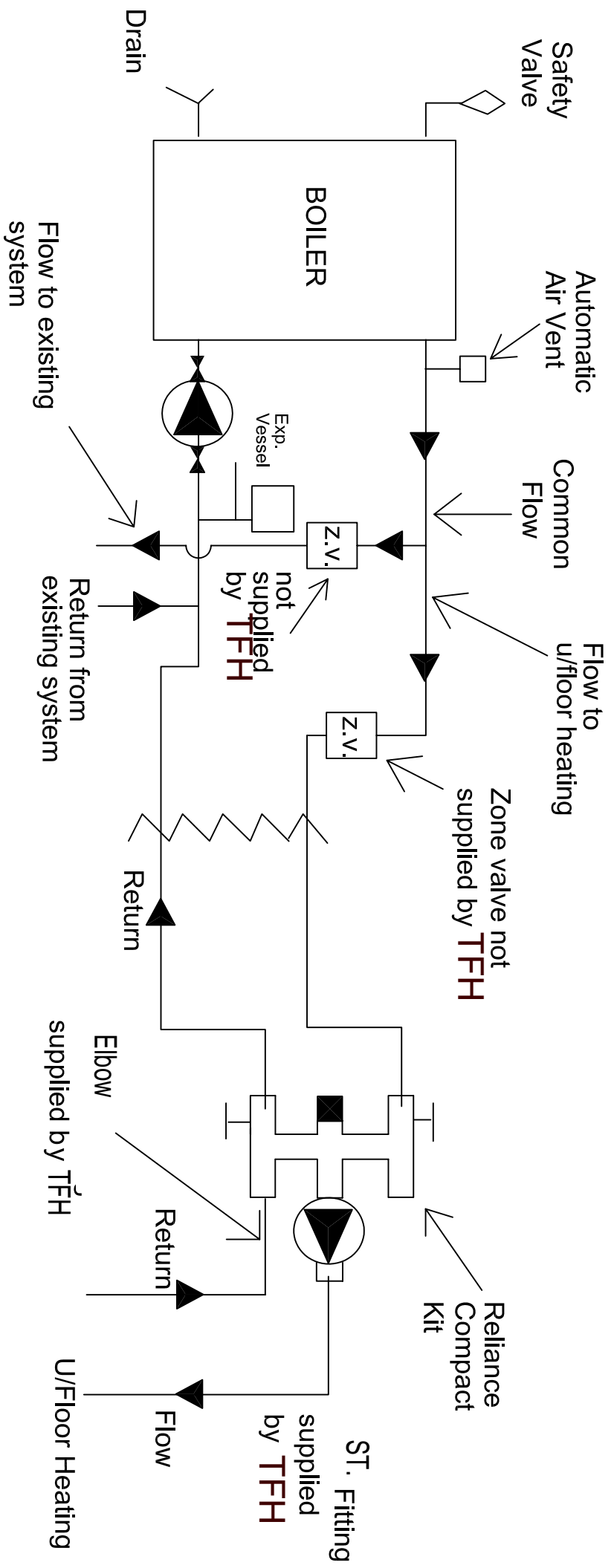

Note - For distances between compact unit and boiler of up to 6 metres 15mm pipe will do. Above this we would require 22mm.

Fig. 1

System Wiring

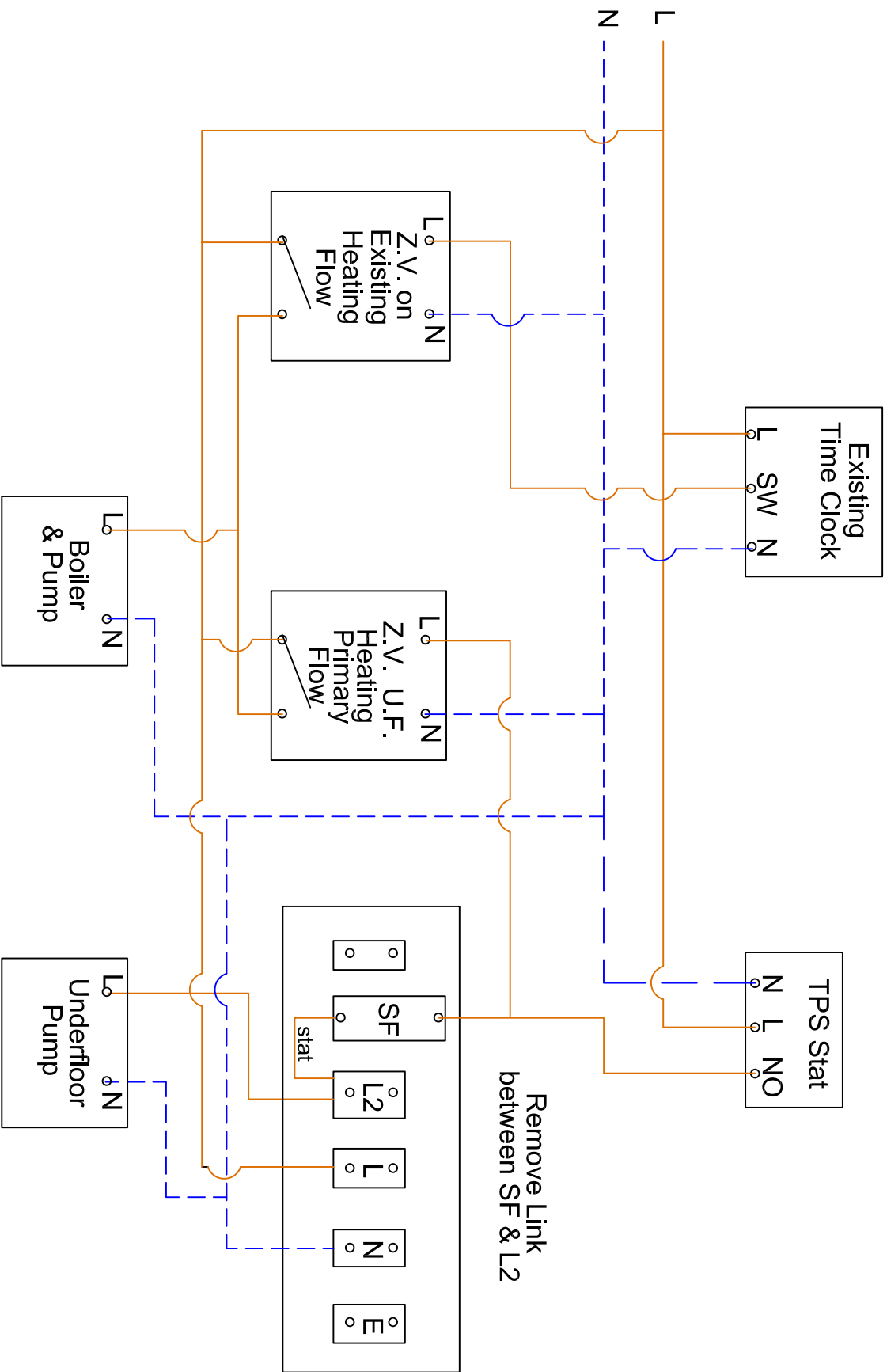

NOTE - For The Sake Of Clarity Earth Wires Are Not Shown But Should Be Installed Were Necessary.

NOTE - If The Electrical Load Of The Boiler And Pump Exceeds Exceeds 3 Amps They Should Be Wired Via A Relay.

Fig. 2