

280 litre Solar T/store heated from oil or gas boiler with connections for radiator circuit, towel rail circuit or oxygen barrier u/f system.

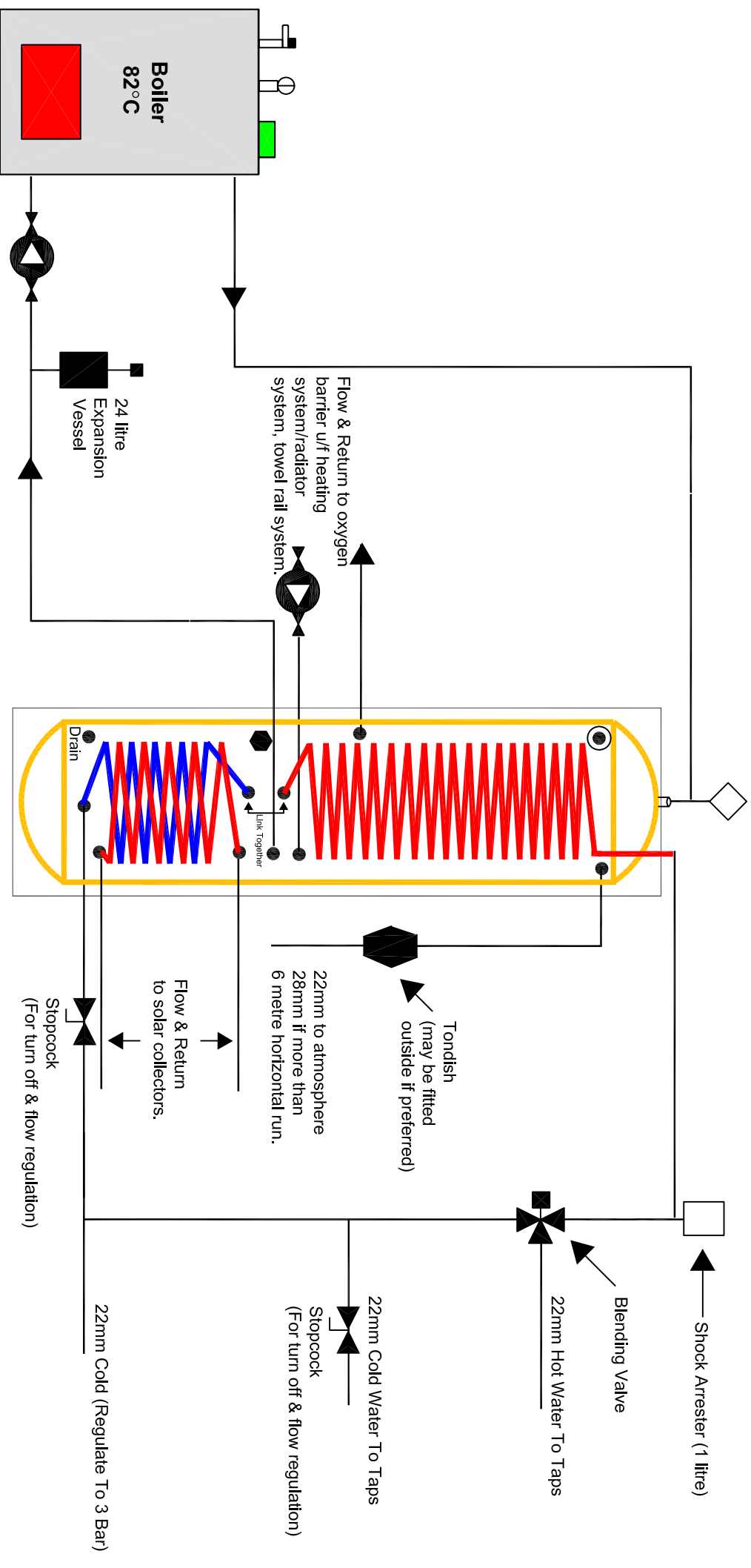

* Link double arrows

** Expansion vessel size shown is usual size for this type of installation, but boiler size & length of pipe runs may alter this.

UFD6 - 280ST/EHW/SOL/R/TR