

280 litre Solar T/store heated from oil or gas boiler with connections for radiator circuit, towel rail circuit or floor heating system.

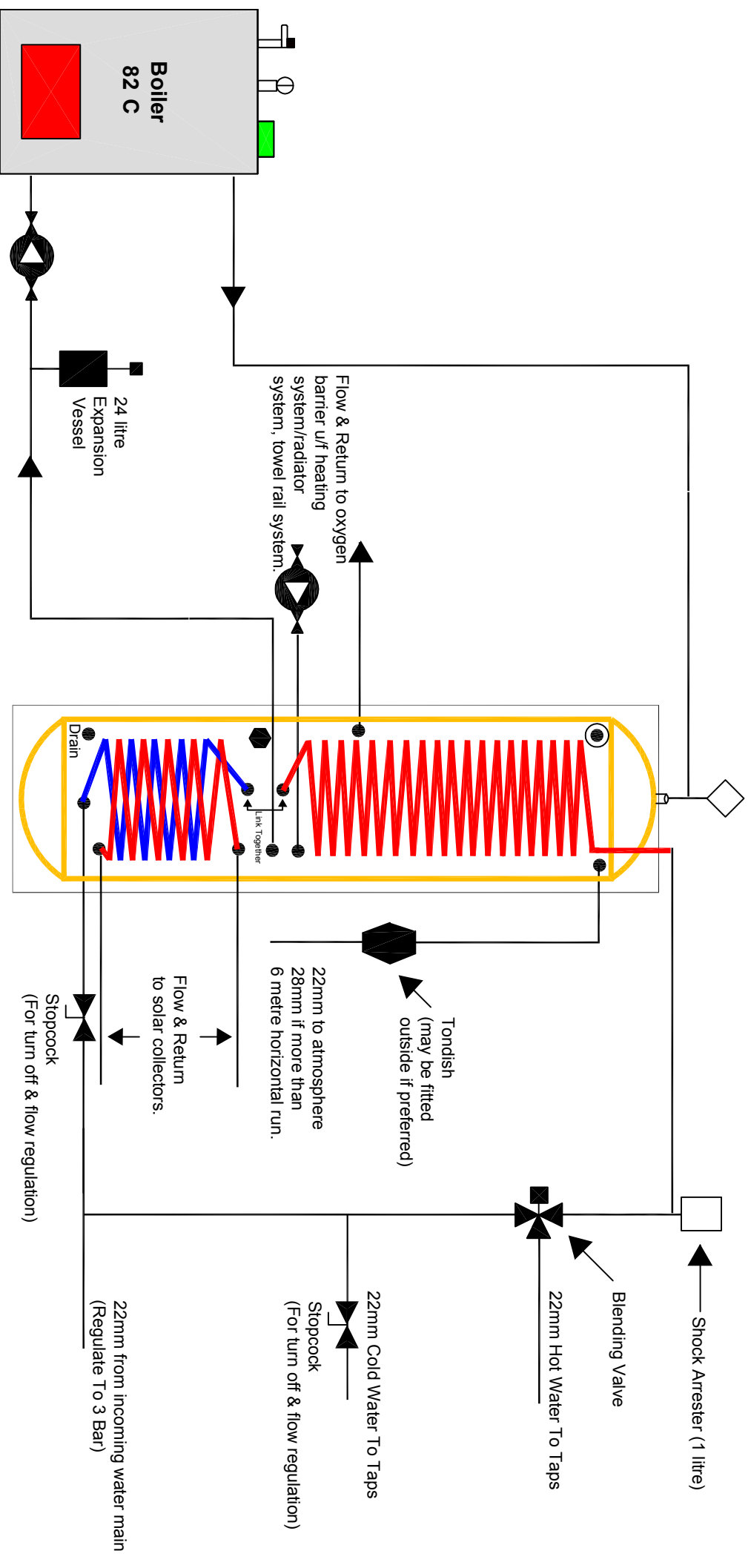

* Link double arrows with external pipework.

** Expansion vessel size shown is usual size for this type of installation, but boiler size & length of pipe runs may alter this.

TFH01-02